

Applications

- Disposal or Injection Tubing
- Production Tubing - ESP, Gas Lift or Rod Pump
- Casing Liners
- Chemical Waste Disposal
- Geothermal
- Slotted Production Liners and Prepacked Screens
- Observation Well Casing

Product Description

- Pressure - Up to 4000 psi (27,6 MPa)
- Resin System - Aliphatic Amine Cured Epoxy
- Reinforcement - Premium Fiberglass
- Joining Systems - API 5B 8rd, Threaded and Coupled or Integral Joint
- Joint Length - 30 Feet (9,1 mts) Nominal 28 to 32 feet (8,5 to 9,8 meters)
- Temperature - Up to 200° F (93.3° C) Maximum
- Sizes - 1.9 through 9 5/8 inches
- Fittings - A variety of filament wound API 5B threaded Nipples and Couplings

Benefits

- Corrosion Control
- Improved Flow Efficiency
- Easily Drilled Up
- Excellent Logging Characteristics

Tubing Design

- Non API Design
- Design Temperature - 200° F (93.3° C)
- Design - Based on the Proportional Elastic Limit in both the Hoop and Axial direction
- 100% Factory Hydrotest - All sizes to 1.25 x Pressure Rating
- Tensile Test - The hydrotest is across the joint and unrestrained; therefore, tensile loads of a proportional amount are generated.

Flow Factors

- Hazen-Williams C=150
- Absolute Roughness=0.00021 in. (0.00533 mm)

Nominal Moduli

- Modulus of Elasticity
Hoop - 5.0 x 106 psi (34.5 GPa)
Axial - 3.0 x 106 psi (20.7 GPa)

Physical Properties

- Density = 122 lbs/cu ft (1.96 kgs/lt)
- Specific Gravity = 1.96

Thermal Properties

- Coefficient of Thermal Conductivity
0.23 BTU/(ft•hr•°F) (0.4 W/(m•°C))
- Coefficient of Thermal Expansion
8.7 x 10⁻⁶ in/in/°F (15,7 x 10⁻⁶ mm/mm/°C)

API 5B THREADS (EUE 10rd, EUE 8rd, OD 8rd)

- Advanced Composite Thread
- Precision molded with Epoxy, Graphite and Ceramic
- Tighter tolerances than steel
- Improved make and break properties
- Minimizes thread and wrench damage
- Chemically resistant threads
- Compatible with steel API 5B Threads

Joining System

Threaded and Coupled (T&C)

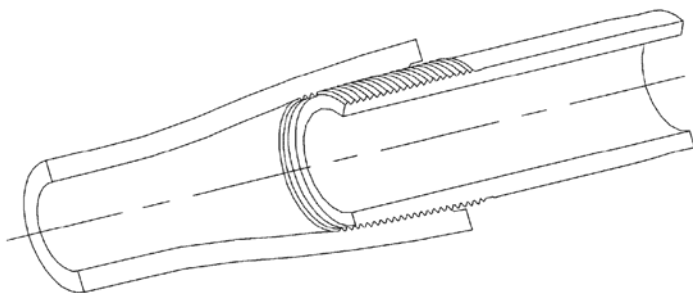

Integral Joint (IJ)

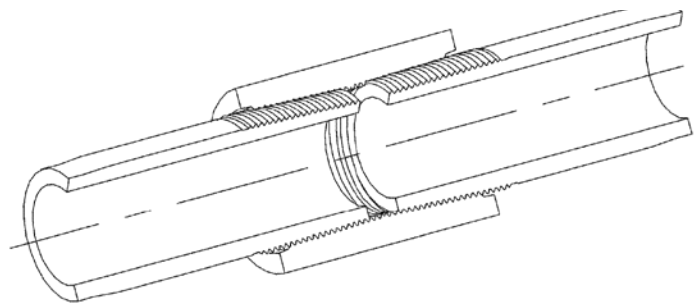

Size	Nominal Pipe Dimensions								IJ ⁽²⁾		T&C ⁽²⁾		Tensile		Collapse	
	Inside Diameter		Drift Diameter		Outside Diameter		Tubing Weight ⁽¹⁾		Connection Diameter		Connection Diameter		Rating ⁽³⁾		Rating ⁽³⁾	
	Thread	in	(mm)	in	(mm)	in	(mm)	Lbs/ft	(kg/m)	in	(mm)	in	(mm)	Lbs	kgs	PSI

Series 1000 (6,9 MPa) - ACT

2½	2.37	(60,2)	2.28	(57,8)	2.64	(67,1)	1.10	(1,6)	3.80	(96,5)	3.80	(96,5)	8000	(3629)	1000	(6,9)
3½	2.94	(74,7)	2.82	(71,5)	3.26	(82,8)	1.50	(2,2)	4.35	(110,5)	4.60	(116,8)	11500	(5216)	1000	(6,9)
4	3.33	(84,6)	3.21	(81,4)	3.74	(95,0)	2.40	(3,6)	-	-	5.00	(127,0)	15000	(6804)	1000	(6,9)
4½	3.85	(97,8)	3.71	(96,6)	4.27	(108,5)	2.60	(3,9)	5.60	(142,2)	5.80	(147,3)	20000	(9072)	1000	(6,9)
5½	4.74	(120,4)	4.62	(117,2)	5.23	(132,8)	3.70	(5,5)	-	-	6.25	(158,8)	38000	(17237)	1200	(8,3)
6¾	5.50	(139,7)	5.38	(136,5)	6.02	(152,9)	4.30	(6,4)	7.45	(189,2)	7.55	(191,8)	45000	(20412)	1000	(6,9)
6¾	5.93	(150,6)	5.81	(147,4)	6.57	(166,9)	5.40	(8,0)	7.55	(191,8)	7.55	(191,8)	55000	(24948)	1000	(6,9)
8¾	7.74	(196,6)	7.62	(193,4)	8.49	(215,6)	8.50	(12,6)	9.60	(243,8)	9.70	(246,4)	90000	(40824)	1000	(6,9)

Series 1500 (10,3 MPa) - ACT

1.90	1.44	(36,6)	1.35	(34,2)	1.74	(44,2)	0.70	(1,0)	2.60	(66,0)	2.80	(71,1)	5000	(2268)	1500	(10,3)
2¾	1.94	(49,3)	1.85	(46,9)	2.33	(59,2)	1.10	(1,6)	3.20	(81,3)	3.25	(82,6)	11500	(5216)	2400	(16,5)
2¾	2.37	(60,2)	2.28	(57,8)	2.72	(69,1)	1.30	(1,9)	3.80	(96,5)	3.80	(96,5)	14000	(6350)	2000	(13,8)
3½	2.94	(74,7)	2.82	(71,5)	3.34	(84,8)	1.90	(2,8)	4.45	(113,0)	4.60	(116,8)	18900	(8392)	1600	(11,0)
4	3.33	(84,6)	3.21	(81,4)	3.77	(95,8)	2.50	(3,7)	-	-	5.00	(127,0)	25000	(11340)	1800	(12,4)
4½	3.85	(97,8)	3.73	(94,6)	4.42	(112,3)	3.50	(5,2)	5.80	(147,3)	5.80	(147,3)	34000	(15422)	1800	(12,4)
5½	4.74	(120,4)	4.62	(117,2)	5.41	(137,4)	4.90	(7,3)	-	-	6.60	(167,6)	48000	(21773)	1800	(12,4)
6¾	5.50	(139,7)	5.38	(136,5)	6.20	(157,5)	5.70	(8,5)	7.65	(194,3)	7.90	(200,7)	60000	(27216)	1800	(12,4)
7	5.93	(150,6)	5.81	(147,4)	6.72	(170,7)	7.00	(10,4)	8.40	(213,4)	8.40	(213,4)	75000	(34020)	1800	(12,4)
9¾	7.74	(196,6)	7.62	(193,4)	8.78	(223,0)	13.20	(19,6)	11.40	(289,6)	11.50	(292,1)	125000	(56700)	1800	(12,4)

Series 1750 (12,1 MPa) - ACT

2¾	1.94	(49,3)	1.85	(46,3)	2.33	(59,2)	1.20	(1,8)	3.30	(83,8)	3.40	(86,4)	12000	(5443)	2400	(16,5)
2¾	2.37	(60,2)	2.28	(57,8)	2.78	(70,6)	1.60	(2,4)	3.90	(99,1)	4.00	(101,6)	16000	(7258)	2200	(15,2)
3½	2.94	(74,7)	2.82	(71,5)	3.39	(86,1)	2.00	(3,0)	4.50	(114,3)	4.80	(121,9)	21000	(9526)	1900	(13,1)
4	3.33	(84,6)	3.21	(81,4)	3.90	(99,1)	3.10	(4,6)	-	-	5.25	(133,4)	30000	(13608)	1800	(12,4)
4½	3.85	(97,8)	3.73	(94,6)	4.43	(112,5)	3.60	(5,4)	6.00	(152,4)	6.10	(154,9)	38000	(17237)	2000	(13,8)
5½	4.74	(120,4)	4.62	(117,2)	5.48	(139,2)	5.40	(8,0)	-	-	6.75	(171,5)	53000	(24041)	2000	(13,8)

Series 2000 (13,8 MPa) - ACT

1.90	1.44	(36,6)	1.35	(34,2)	1.74	(44,2)	0.70	(1,0)	2.70	(68,6)	2.80	(71,1)	7500	(3402)	2800	(19,3)
2¾	1.94	(49,3)	1.85	(46,9)	2.37	(60,2)	1.40	(2,1)	3.40	(86,4)	3.40	(86,4)	14500	(3402)	2800	(19,3)
2¾	2.37	(60,2)	2.28	(57,8)	2.78	(70,6)	1.60	(2,4)	4.00	(101,6)	4.00	(101,6)	18000	(6577)	2400	(16,5)
3½	2.94	(74,7)	2.82	(71,5)	3.44	(87,4)	2.30	(3,4)	4.70	(119,4)	4.80	(121,9)	25000	(8165)	2300	(15,9)
4	3.33	(84,6)	3.21	(81,4)	3.91	(99,3)	3.20	(4,8)	-	-	5.25	(133,4)	34000	(11340)	2300	(15,9)
4½	3.85	(97,8)	3.73	(94,6)	4.56	(115,8)	4.40	(6,5)	6.20	(157,5)	6.10	(154,9)	45000	(15422)	2300	(15,9)
5½	4.74	(120,4)	4.62	(117,2)	5.48	(139,2)	5.50	(8,2)	-	-	7.00	(177,8)	53000	(20412)	2000	(13,8)
6¾	5.50	(139,7)	5.38	(136,5)	6.38	(162,1)	7.30	(10,9)	8.00	(203,2)	8.25	(209,6)	70000	(31752)	2200	(15,2)
7	5.93	(150,6)	5.81	(147,6)	6.93	(176,0)	9.20	(13,7)	8.70	(221,0)	8.75	(222,3)	90000	(40824)	2200	(15,2)
9¾	7.74	(196,6)	7.62	(193,4)	9.08	(230,6)	16.10	(24,0)	11.75	(298,5)	11.90	(302,3)	160000	(72576)	2200	(15,2)

Size	Nominal Pipe Dimensions								IJ ⁽²⁾		T&C ⁽²⁾		Tensile		Collapse	
	Inside Diameter		Drift Diameter		Outside Diameter		Tubing Weight ⁽¹⁾		Connection Diameter		Connection Diameter		Rating ⁽³⁾		Rating ⁽³⁾	
	Thread	in	(mm)	in	(mm)	in	(mm)	Lbs/ft	(kg/m)	in	(mm)	in	(mm)	Lbs	(kgs)	PSI

Series 2500 (17,2 MPa) - ACT

1.90	1.44	(36,6)	1.35	(34,2)	1.89	(48,0)	1.10	(1,6)	2.80	(71,1)	2.90	(73,7)	10000	(4536)	3300	(22,8)
2½	2.94	(49,3)	1.85	(46,9)	2.47	(62,7)	1.70	(2,5)	3.50	(88,9)	3.60	(91,4)	17000	(7711)	3300	(22,8)
2¾	2.37	(60,2)	2.28	(57,8)	2.90	(73,7)	2.00	(3,0)	4.20	(106,7)	4.20	(106,7)	22000	(9979)	3000	(20,7)
3½	2.94	(74,7)	2.82	(71,5)	3.58	(90,9)	2.90	(4,3)	4.90	(124,5)	5.10	(129,5)	30000	(13608)	2600	(17,9)
4	3.33	(84,6)	3.21	(81,4)	4.05	(102,9)	3.90	(5,8)	-	-	5.55	(141,0)	40000	(18144)	2700	(18,6)
4½	3.85	(97,8)	3.73	(94,6)	4.68	(118,9)	5.10	(7,6)	6.50	(165,1)	6.40	(162,6)	55000	(24948)	2700	(18,6)

Series 3000 (20,7 MPa) - ACT

1.90	1.44	(36,6)	1.35	(34,2)	1.87	(47,5)	1.10	(1,6)	3.00	(76,2)	3.05	(77,5)	11000	(4990)	3700	(25,5)
2½	1.94	(49,3)	1.85	(46,9)	2.51	(63,8)	1.80	(2,7)	3.70	(94,0)	3.70	(94,0)	20000	(9072)	3600	(24,8)
2¾	2.37	(60,2)	2.28	(57,8)	2.98	(75,7)	2.40	(3,6)	4.40	(111,8)	4.40	(111,8)	26500	(12020)	3400	(23,4)
3½	2.94	(74,7)	2.82	(71,5)	3.70	(94,0)	3.50	(5,2)	5.10	(129,5)	5.25	(133,4)	36500	(16556)	3200	(22,1)
4	3.33	(84,6)	3.21	(81,4)	4.16	(105,7)	4.40	(6,5)	-	-	5.85	(148,6)	45000	(20412)	3200	(22,1)
5½	3.85	(97,8)	3.73	(94,6)	4.83	(122,7)	6.80	(10,1)	-	-	7.60	(193,0)	66000	(29938)	3200	(22,1)

Series 3500 (24,1 MPa) - ACT

1.90	1.44	(36,6)	1.35	(34,2)	1.96	(49,8)	1.30	(1,9)	3.20	(81,3)	3.15	(80,0)	13000	(5897)	4400	(30,3)
2½	1.94	(49,3)	1.85	(46,9)	2.57	(65,3)	2.10	(3,1)	3.85	(97,8)	3.90	(99,1)	21500	(9752)	3900	(26,9)
2¾	2.37	(60,2)	2.28	(57,8)	3.07	(78,0)	2.80	(4,2)	4.60	(116,8)	4.60	(116,8)	30000	(13608)	3700	(25,5)
4½	2.94	(74,7)	2.82	(71,5)	3.83	(97,3)	5.00	(7,4)	-	-	7.00	(177,8)	44000	(19958)	3700	(25,5)
4¾	3.33	(84,6)	3.21	(81,4)	4.28	(108,7)	5.60	(8,3)	-	-	7.00	(177,8)	50000	(22680)	3600	(24,8)
5½	3.85	(97,8)	3.73	(94,6)	5.04	(128,0)	8.20	(12,2)	-	-	7.90	(200,7)	78000	(35381)	3600	(24,8)

Pipe Capacity

Size	Inside Diameter		Capacity	
	Thread	in	(mm)	Bbls/1,000 ft.
1.90	1.50	(38,1)	2.20	(1,1)
2½	1.94	(49,3)	3.70	(1,9)
2¾	2.37	(60,2)	5.40	(2,8)
3½	2.94	(74,7)	8.40	(4,4)
4	3.33	(84,6)	10.80	(5,6)
4½	3.85	(97,8)	14.40	(7,5)
4¾	3.91	(99,3)	14.80	(7,7)
5½	4.74	(120,4)	21.80	(11,4)
6¾	5.50	(139,7)	29.40	(15,3)
7	5.93	(150,6)	34.20	(17,8)
8¾	7.74	(196,6)	58.10	(30,3)
9¾	7.74	(196,6)	58.10	(30,3)

Joining System Information

API THREADED SIZE - Inches	1½		2¾		2¾		3½		4			
Thread Type⁽²⁾	EUE 10rd		EUE 8rd		EUE 8rd		EUE 8rd		EUE 8rd			
Thread Length - in (mm)	2.36	(59,9)	2.94	(74,7)	3.25	(82,6)	3.50	(88,9)	4.00	(101,6)		
Make-Up Length Loss - in/Jt (mm/Jt)	2.06	(52,4)	2.56	(65,1)	2.88	(73,0)	3.13	(79,4)	3.88	(98,4)		
Make-Up Torque - ft. Lbs. (mm)	Optimum	125	(170)	150	(204)	185	(252)	225	(306)	700	(374)	
	Minimum	100	(136)	125	(170)	150	(204)	175	(238)	475	(306)	
	Maximum	175	(238)	225	(306)	250	(340)	300	(408)	825	(510)	
Recommended Make-Up Tool	No. 5 Strap								No.11 Strap			
Pin Upset O.D. - in (mm)	2.15	(54,6)	260	(66,0)	3.10	(78,7)	3.75	(95,3)	4.25	(219,9)		
Handling Tools												
Elevators T&C (Shoulder Type) - in⁽⁵⁾	2¾		2¾		3½		4½		4½			
Elevators IJ (Slip Type)⁽⁶⁾	MYT		MYT		MYT		YT		YT			
Floor Slips (Standard Type) - in⁽⁷⁾	1½		2¾		2¾		3½		4			
Thread Compatibility FRP Long vs. Steel Short Form⁽²⁾ (Extra Threads, Front of FRP Pin)	6		5		6		6		6			
Lubricant Usage (Joints/Gallon)	100		100		100		100		100			
Stretch Factor	(in/per 100 ft)	Series	in	(mm)	in	(mm)	in	(mm)	in	(mm)		
	(mm/per 30.5)	1000	-	-	-	-	3.77	(95,6)	2.57	(65,2)	1.76	(44,6)
		1500	5.34	(135,6)	3.06	(77,7)	2.86	(72,6)	2.03	(51,5)	1.63	(41,4)
		1750	-	-	3.06	(77,7)	2.41	(61,3)	1.79	(45,4)	1.24	(31,4)
		2000	5.34	(135,6)	2.75	(69,8)	2.41	(61,3)	1.60	(40,6)	1.21	(30,8)
		2500	3.40	(86,3)	2.18	(55,3)	1.82	(46,3)	1.22	(31,0)	0.96	(24,3)
		3000	3.58	(90,9)	2.01	(51,0)	1.56	(39,6)	1.01	(25,6)	0.82	(20,8)
		3500	2.88	(73,2)	1.79	(45,5)	1.34	(34,0)	-	-	-	-
Tensile Ultimates⁽⁴⁾	psi (MPa)		25,000	(172,3)	46,000	(317,1)	58,000	(399,8)	74,000	(510,2)	90,000	(612,4)

API THREADED SIZE - Inches			4½	5½	6⅝	7	8⅝	9⅝
Thread Type⁽²⁾			EUE 8rd	OD 8rd	OD 8rd	OD 8rd	OD 8rd	OD 8rd
Thread Length - in (mm)			3.88 (98,6)	4.74 (120,7)	4.25 (108,0)	4.85 (123,2)	4.85 (123,2)	5.13 (130,3)
Make-Up Length Loss - in/Jt (mm/Jt)			3.50 (88,9)	4.38 (98,4)	3.88 (98,4)	4.50 (114,3)	4.50 (114,3)	4.75 (120,7)
Make-Up Torque - ft. Lbs. (mm)	Optimum		300 (408)	400 (544)	500 (680)	525 (714)	700 (952)	630 (857)
	Minimum		250 (340)	320 (436)	400 (544)	420 572	475 (646)	500 (680)
	Maximum		450 (612)	560 (612)	650 (884)	735 1000	825 (1122)	880 (1200)
Recommended Make-Up Tool			No. 11 Strap	Approved Power Tongs				
Pin Upset O.D. - in (mm)			4.75 (120,7)	5.55 (141,0)	6.65 (168,9)	7.05 (179,1)	8.65 (219,9)	9.65 (245,1)
Handling Tools								
Elevators T&C (Shoulder Type) - in ⁽⁵⁾			5½	6⅝	7	7⅝	9⅝	10¾
Elevators IJ (Slip Type) ⁽⁶⁾			YC	YC	MYT	YT	YT	Slip Type
Floor Slips (Standard Type) - in ⁽⁷⁾			4½	5½	6⅝	7	8⅝	9⅝
Thread Compatibility FRP Long vs. Steel Short Form ⁽²⁾ (Extra Threads, Front of FRP Pin)			7	5	6	7	9	11
Lubricant Usage (Joints/Gallon)			50	34	34	26	26	26
Stretch Factor	(in/per 100 ft)	Series	in (mm)	in (mm)	in (mm)	in (mm)	in (mm)	in (mm)
	(mm/per 30.5)	1000	1.49 (37,9)	1.04 (26,5)	** **	- -	0.42	- -
		1500	1.08 (27,4)	0.75 (19,0)	0.62 (15,8)	0.51 (12,9)	- -	0.30 (7,5)
		1750	1.06 (26,9)	0.67 (17,1)	- -	- -	- -	- -
		2000	0.85 (21,7)	0.67 (17,1)	0.49 (12,4)	.40 (10,1)	- -	0.23 (5,7)
		2500	0.72 (18,3)	- -	- -	- -	- -	- -
		3000	- -	0.60 (15,2)	- -	- -	- -	- -
		3500	* *	0.48 (12,2)	- -	- -	- -	- -
Tensile Ultimates⁽⁴⁾	psi (MPa)		100,000 (689,4)	130,000 (896,3)	140,000 (965,2)	175,000 (1206,5)	185,000 (1275,5)	210,000 (1447,8)

NOTE: These guidelines can vary depending on actual well conditions. A STAR Well will provide more accurate setting tension/stretch.

* 4½” thread (3” pipe), 3500 psi, the stretch factor is 0.85; 4½” thread (3½” pipe), 3500 psi, the stretch factor is 0.70.

** 6⅝” thread (5.50 ID), 1000 psi, the stretch factor is .085; 6⅝” thread (5.93 ID) 1000 psi, the stretch factor is 0.64.

Corresponding Numbered Notes:

- 1. Tubing Weight** is based on Threaded and Coupled (T&C) Joining System.
- 2. Threads** - All 1½" EUE 10rd and 2¾"- 4½" EUE 8rd API threads conform to API 5B Table 14, 14th Edition (L4 is minimum) and all 5½"- 9⅝" O.D. 8rd casing threads conform to API 5B, Table 7, 14th Edition (L4 is minimum).
- 3. Ratings** - All ratings are maximum operating limits. Exceeding these limits will void the warranty on all NOV Fiber Glass Systems pipe.
- 4. Tensile Ultimates** - The typical mode of failure for pressure is weep and for tensile it is an across the joint pipe body shear.
- 5. Elevators T&C** - The 1000 & 1500 psi products have smaller OD's which may work with the same size elevators as the thread size.
- 6. Elevators IJ** - The setting plate must be removed so that the slips will properly set on the fiberglass pipe. Sizing slip type elevators requires use of the tubing O.D. instead of the upset O.D. on the male end. Rubber setting plates are available to minimize marking and to improve the fit. Shorter bolts are required to hold in place.
- 7. Floor Slips** - When running lighter weight (1000-1500 psi) products, it is good practice to replace the slip dies to make sure they will latch on the pipe body.

Packer Selection

(More information listed in "Downhole Tubing and Casing Installation and Application Practices" Manual)

- STAR tubing is designed to be set in tension (see stretch chart).
- Double Grip Packers are preferred with an on/off tool seal assembly, ¼ turn release.
- Direct Tension Set Packers should be avoided due to the movement of fiberglass.
- Direct Set Packers are set <3500 feet deep (1,067 m).
- When packer setting is >3500 feet (1,067 m) deep, use steel work string to set packer.
- Hydraulic Set Packers are not recommended due to uncontrollable forces.
- Polished Bore Receptacles are set with proper precautions to avoid compression. A complete STAR Well Evaluation must be performed to determine the proper set-ups.

Perforation

- Use a Jet Perforating Gun. Shoot a maximum of two shots at a time at 0° Phase or 180° Phase.
- Thread lock all steel to FRP connections.
- When installing mixed strings, have one joint of FRP casing supplied without a coupling (pin x pin) for cross-overs.

Cementing

- Cementing in two stages may help avoid exceeding collapse rating.
- Keep differential below external and internal ratings at all times.
- Care must be given to avoid shock collapse pressure when setting cement plug.
- Fiberglass centralizers are available, metal centralizers must be qualified to fit to FRP.
- Cement residue can be cleaned up with proper care using a rock bit.
- Landing joints are available, but must be sized for the well-head selected.
- Drilling-Up fiberglass tubing or casing is easy with a rock bit (not a mill).

Rod Pump Wells

- It is preferred that the tubing be anchored.
- Rod Guides must be used.

Electric Submersible Pumps

- Care must be given to direction and amount of start-up torque.

Fishing

- Normal Procedures, Spear or Overshot.

Cutting

- Mechanical Jet Cutter.